

# Electrode for bolt welding

## Water cooling jacket

● mark and blue letter means ordered product.



► By cooling effect, this gives longer life of electrode and prevention from lowering conductivity by heat ascension.



► This matches with various kinds of holders.

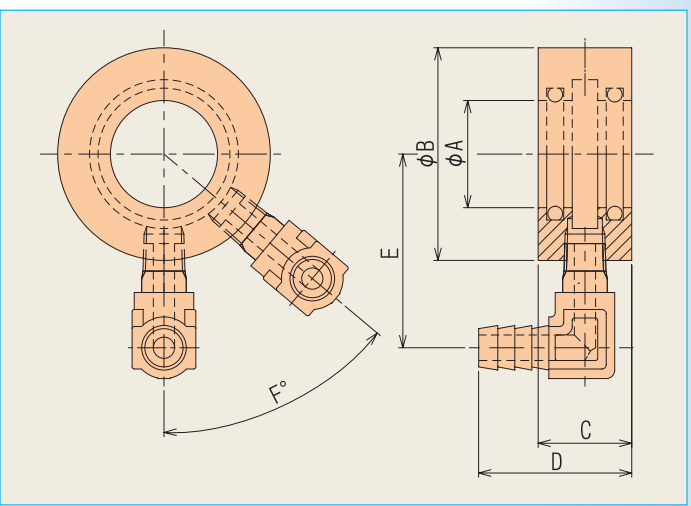
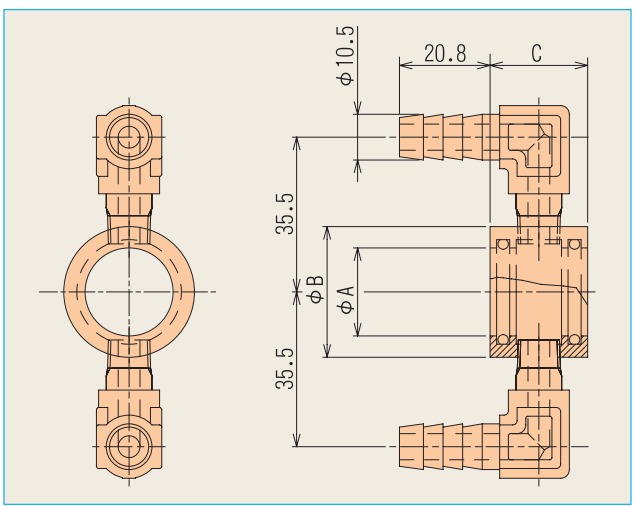

Order code

## Water cooling jacket Code I model / II model

Unit : mm

Code	A	B		C		O ring
		I model (Without screw)	II model (With screw)	I model	II model	
18	● I model	18.2	30	22.4		P18
	II model	18.2	30		26.5	P18
20	I model	20.2	30	22.4		P20
	II model	20.2	30		26.5	P20
30	I model	30.2	55	22.0		P30
	II model	30.2	50		32.0	P30

Unit : mm

Code	A	B		C		D	E	F	O ring
		I model (Without screw)	II model (With screw)	I model	II model				
25	I model	25.2	50		22	36	45.5	50	P25
	II model	25.2		45	32	43.5	43	50	P25
32	I model	32.2	55		22	36	48	50	P32
	II model	32.2		50	32	43.5	45.5	50	P32



► Prevent from spatter adhesion on product (Thread at nut, thread at bolt and also for longer life of electrode.)

■ Recommendable set = Saiper + Water cooling jacket (with electrode)

Saiper

+

Water cooling jacket